

Code No: C0402

JAWAHARLAL NEHRU TECHNOLOGICAL UNIVERSITY HYDERABAD

M.TECH I - SEMESTER EXAMINATIONS, APRIL/MAY-2012

FINITE ELEMENT ANALYSIS

(CAD/CAM)

Time: 3hours

Max. Marks: 60

Answer any five questions  
All questions carry equal marks

- - -

- 1.a) Differentiate between planar frame element and space frame element.  
b) Use finite element method to calculate displacements and stresses of the bar shown in the fig. 1.

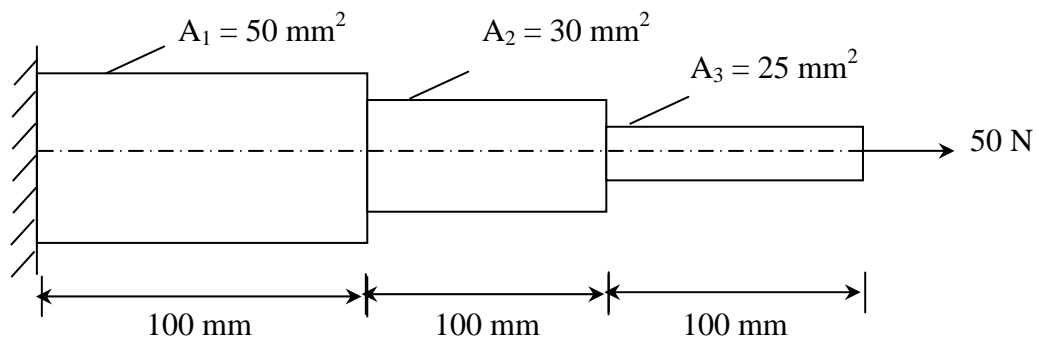
**Fig.1** $E = 200 \text{ Gpa.}$ 

- 2.a) Write about different boundary considerations in beams.  
b) For a beam and loading shown in fig.2, determine the slopes at 2 and 3 and the vertical deflection at the midpoint of the distributed load.

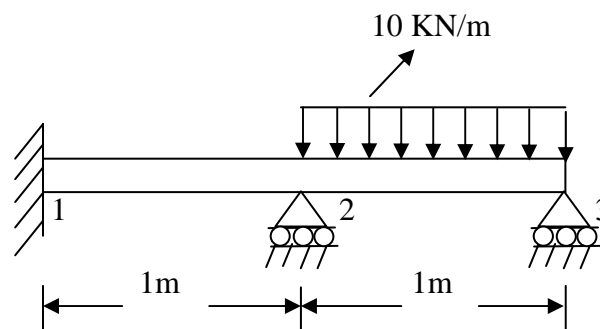
**Fig.2**

Contd....2

3. Explain the steps involved in analysis of beams. With the help of a simple example explain how boundary conditions are applied.
- 4.a) Derive the Equilibrium equations and strain displacement relations for three dimensional bodies.  
b) Discuss in detail about Galerkins Method and Principal of Minimum potential energy and discuss with an example.
- 5.a) An axisymmetric triangular element is subjected to the loading as shown in fig.3 the load is distributed throughout the circumference and normal to the boundary. Derive all the necessary equations and derive the nodal point loads.

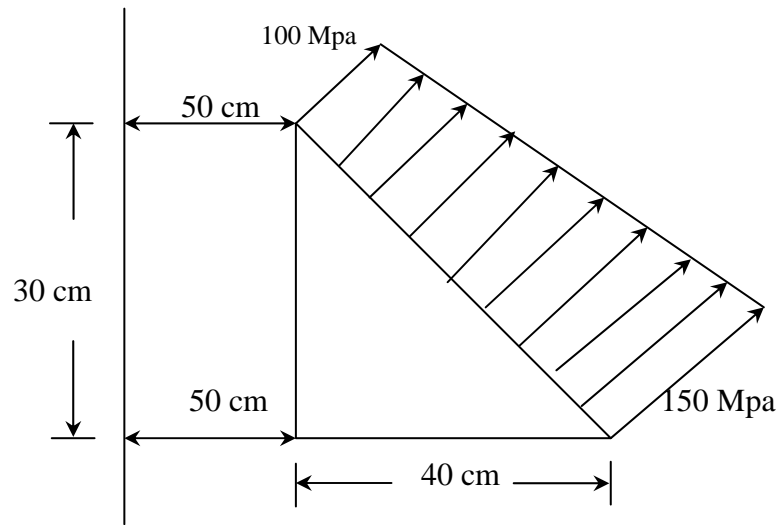

**Fig.3**

- b) How do you calculate element stresses for 3-Dimensional bodies?

**Contd....3**

- 6.a) Discuss in detail about material and Geometrical Non –Linearity and how it is to be incorporated in FEM Formulation
- b) Discuss in detail about Tetrahedron element and their properties and advantages. Derive the [B] matrix, Strian and stresses for four noded Tetrahedron element.
- 7.a) Distinguish between consistent mass matrix and Lumped mass matrix..
- b) Derive one dimensional steady state heat conduction equation and apply for one dimensional fin problem. Determine the temperature distribution in a straight fin of circular cross section. Use three one dimensional linear elements and assume that the tip is insulated. Diameter of fin is 1 cm, length is 6 cm,  $h = 0.6 \text{ W/cm}^2 - ^\circ\text{C}$ ,  $\phi_\infty = 25^\circ\text{C}$  and base temperature is  $\phi_1 = 80^\circ\text{C}$ .
- 8.a) Discuss in detail about the general procedure of FEM formulation.
- b) Derive the Lagrangian and Hermite shape functions for Bar and Beam two noded elements.

---oo0oo---